



PD-128S

PD-128

PD-108

V-Pad

Owner's Manual

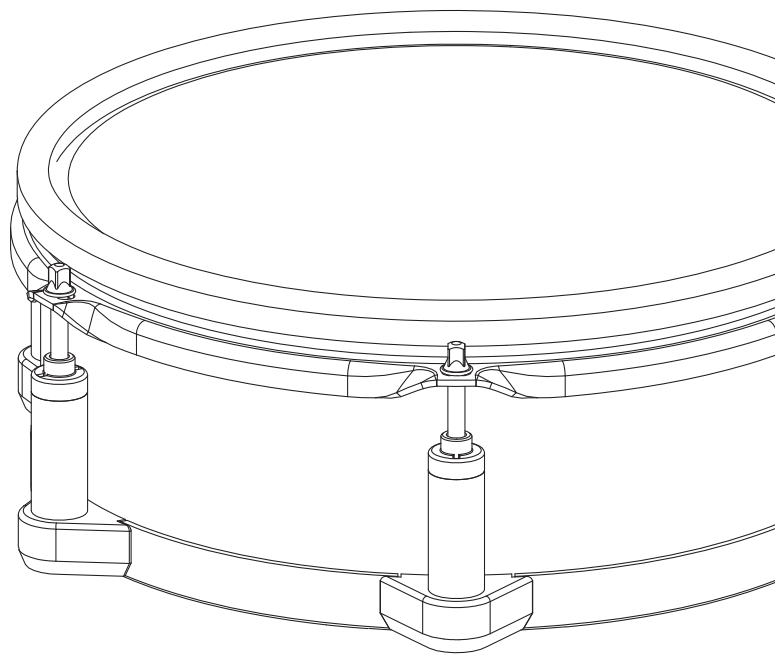

Roland





* 5 1 0 0 0 2 5 6 4 4 - 0 1 *



USING THE UNIT SAFELY

INSTRUCTIONS FOR THE PREVENTION OF FIRE, ELECTRIC SHOCK, OR INJURY TO PERSONS

About ⚠ WARNING and ⚠ CAUTION Notices

 WARNING	Used for instructions intended to alert the user to the risk of death or severe injury should the unit be used improperly.
 CAUTION	Used for instructions intended to alert the user to the risk of injury or material damage should the unit be used improperly. * Material damage refers to damage or other adverse effects caused with respect to the home and all its furnishings, as well to domestic animals or pets.

About the Symbols

	The ⚠ symbol alerts the user to important instructions or warnings. The specific meaning of the symbol is determined by the design contained within the triangle. In the case of the symbol at left, it is used for general cautions, warnings, or alerts to danger.
	The ⊘ symbol alerts the user to items that must never be carried out (are forbidden). The specific thing that must not be done is indicated by the design contained within the circle. In the case of the symbol at left, it means that the unit must never be disassembled.
	The ⚡ symbol alerts the user to things that must be carried out. The specific thing that must be done is indicated by the design contained within the circle. In the case of the symbol at left, it means that the power-cord plug must be unplugged from the outlet.

ALWAYS OBSERVE THE FOLLOWING

WARNING

Do not disassemble or modify by yourself

Do not open or perform any internal modifications on the unit. (The only exception would be where this manual provides specific instructions which should be followed in order to put in place user-installable options; see p. 8.)



Do not repair or replace parts by yourself

Do not attempt to repair the unit, or replace parts within it (except when this manual provides specific instructions directing you to do so). Refer all servicing to your retailer, the nearest Roland Service Center, or an authorized Roland distributor, as listed on the "Information" page.



Do not use or store in the following types of locations

- Subject to temperature extremes (e.g., direct sunlight in an enclosed vehicle, near a heating duct, on top of heat-generating equipment); or are
- Damp (e.g., baths, washrooms, on wet floors); or are
- Exposed to steam or smoke; or are
- Subject to salt exposure; or are
- Humid; or are
- Exposed to rain; or are
- Dusty or sandy; or are
- Subject to high levels of vibration and shakiness.



Use only stand that is recommended

Mount this unit on a stand recommended by Roland (MDS series) or on a commercially available snare stand that meets the requirements listed on page 5.



WARNING

Do not place in an unstable location

If you mount this unit on a stand (one from the MDS series or a commercially available snare stand), do not place the stand on a surface that is unstable or is inclined.



Place it on a surface that is level and sure to remain stable.

Even if you are using this unit by itself, you should likewise place it on a surface that is level and sure to remain stable.

Don't allow foreign objects or liquids to enter unit; never place containers with liquid on unit

Do not place containers containing liquid on this product. Never allow foreign objects (e.g., flammable objects, coins, wires) or liquids to enter this product. Doing so may cause short circuits, faulty operation, or other malfunctions.



Adults must provide supervision in places where children are present

When using the unit in locations where children are present, be careful so no mishandling of the unit can take place. An adult should always be on hand to provide supervision and guidance.



Do not drop or subject to strong impact

Protect the unit from strong impact.
(Do not drop it!)



CAUTION

Manage cables for safety

Try to prevent cords and cables from becoming entangled. Also, all cords and cables should be placed so they are out of the reach of children.



Avoid climbing on top of the unit, or placing heavy objects on it

Never climb on top of, nor place heavy objects on the unit.



Disconnect the sound module before moving the unit

Before you move the unit, disconnect all external equipment.



Keep small items out of the reach of children

To prevent accidental ingestion of the parts listed below, always keep them out of the reach of small children.



- Removable Parts
Tuning bolts, washers, clips, covering fastening screws

IMPORTANT NOTES

Placement

- Do not expose the unit to direct sunlight, place it near devices that radiate heat, leave it inside an enclosed vehicle, or otherwise subject it to temperature extremes. Excessive heat can deform or discolor the unit.
- When moved from one location to another where the temperature and/or humidity is very different, water droplets (condensation) may form inside the unit. Damage or malfunction may result if you attempt to use the unit in this condition. Therefore, before using the unit, you must allow it to stand for several hours, until the condensation has completely evaporated.
- Do not allow rubber, vinyl, or similar materials to remain on this unit for long periods of time. Such objects can discolor or otherwise harmfully affect the finish.
- Do not put anything that contains water on this unit. Also, avoid the use of insecticides, perfumes, alcohol, nail polish, spray cans, etc., near the unit. Swiftly wipe away any liquid that spills on the unit using a dry, soft cloth.

Maintenance

- For everyday cleaning wipe the unit with a soft, dry cloth or one that has been slightly dampened with water. To remove stubborn dirt, use a cloth impregnated with a mild, non-abrasive detergent. Afterwards, be sure to wipe the unit thoroughly with a soft, dry cloth.
- Never use benzene, thinners, alcohol or solvents of any kind, to avoid the possibility of discoloration and/or deformation.

Additional Precautions

- Use a reasonable amount of care when using the unit's buttons, sliders, or other controls; and when using its jacks and connectors. Rough handling can lead to malfunctions.
- When disconnecting all cables, grasp the connector itself—never pull on the cable. This way you will avoid causing shorts, or damage to the cable's internal elements.
- This instrument is designed to minimize the extraneous sounds produced when it's played. However, since sound vibrations can be transmitted through floors and walls to a greater degree than expected, take care not to allow these sounds to become a nuisance others nearby.
- When you need to transport the unit, package it in the box (including padding) that it came in, if possible. Otherwise, you will need to use equivalent packaging materials.
- The snare stand is supported by means of a tripod. When installing the drum set, make sure the legs of the tripod are opened wide enough to keep the equipment from falling over.
- The rubber portion is treated with a preservative to maintain its performance. With the passage of time, this preservative may appear on the surface as a white stain, or reveal how the pads were struck during product testing. This does not affect the performance or functionality of the product, and you may continue using it with confidence.

- Do not insert your hands or fingers in the locations marked by the arrows. Otherwise, you risk injury and possible damage to this unit's parts.

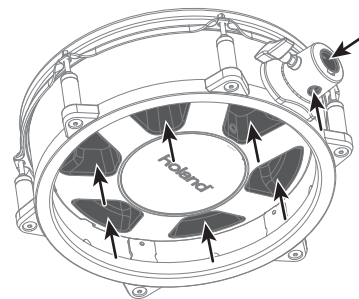

Before using this unit, carefully read the sections entitled: "USING THE UNIT SAFELY" (p. 2) and "IMPORTANT NOTES" (p. 3). These sections provide important information concerning the proper operation of the unit. Additionally, in order to feel assured that you have gained a good grasp of every feature provided by your new unit, Owner's manual should be read in its entirety. The manual should be saved and kept on hand as a convenient reference.

Getting Started

Main Features

- Snare/tom pad with mesh head allowing for excellent feel, dynamics and low level acoustics sound.
- Rim shots and playing with brushes is possible.
- The pad can mount on a V-Drums drum stand and/or commercially available tom stands (vertical rod type or horizontal pipe type p. 5) (PD-128/108 only).
- You can easily change the shell covering to personalize the kit's look.

PD-128S/128/108 Components

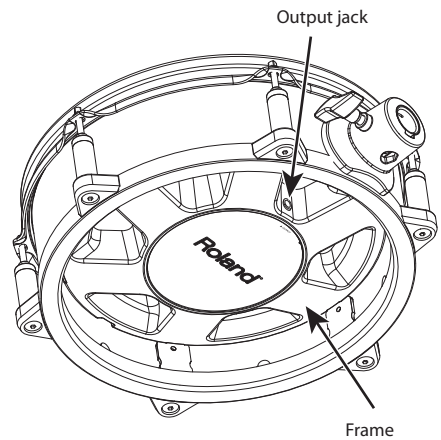
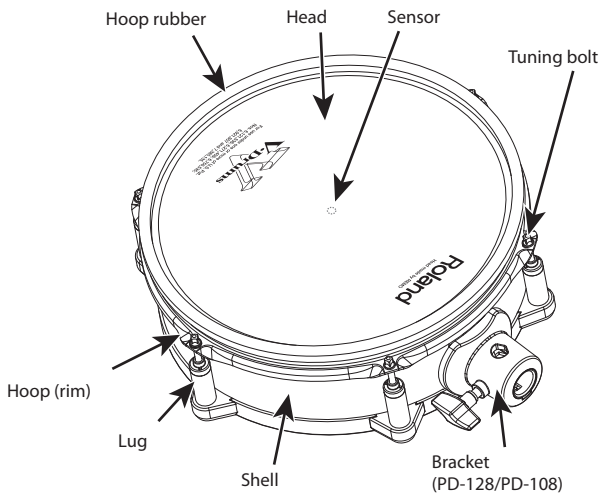

* The illustration shows the PD-128.

- The only difference between the PD-128 and PD-108 is their diameter.
- The PD-128S has no bracket as it's designed for use with a snare stand.

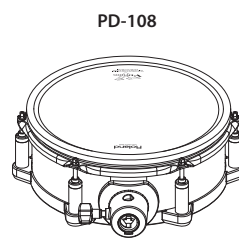
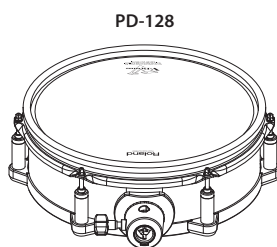
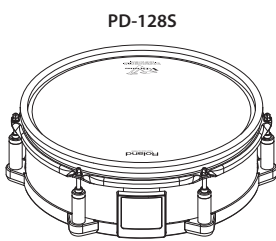

NOTE

- Applying excessive force to the sensor located under the head can damage it.
- Due to the nature of the materials used in the sensor, changes in temperature or humidity may affect playing dynamics or sensor sensitivity.

Mounting the Pads

Mounting the PD-128S (Dedicated Snare Pad)

The PD-128S (dedicated snare pad) has no mounting bracket so can only be used with a snare stand.

Make sure that the snare stand you are using is able to support a 12-inch shell.

MEMO

Since the PD-128S is a dedicated snare pad, it does not have a bracket.

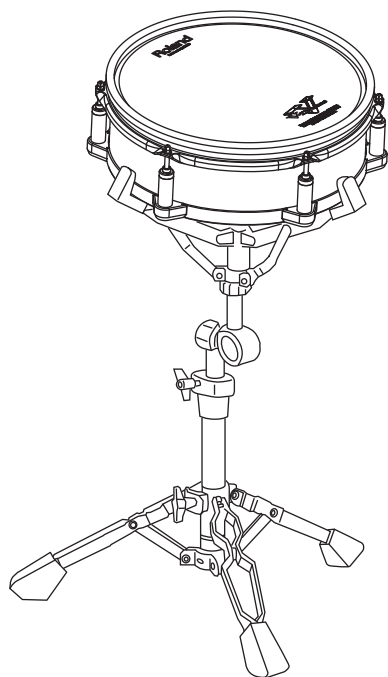

Mounting the PD-128 or 108 on a Tom Stand

The PD-128/108 can be attached to a stand that has either a vertical rod or a horizontal pipe.

Stand with Vertical Rod (MDS Series)

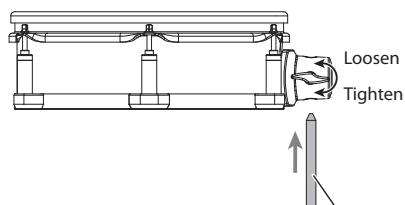

Rod diameter that can be attached: 9–11.5 mm (3/8–1/2 inch)

Stand with Horizontal Pipe

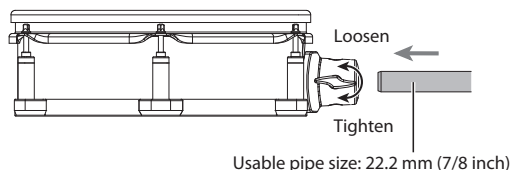

Usable pipe size: 22.2 mm (7/8 inch)

Mounting the PD-128 or 108 on a Snare Stand

It was already mentioned that mounting a PD-128S requires a snare stand that can support a 12-inch shell.

For the PD-108, the stand must support a 10-inch shell.

MEMO

Tighten the knob that fastens bracket securely to assure the best functionality.

Connecting to the Percussion Sound Module

Use the included stereo cables to connect pads to your percussion sound module (sold separately).

Connect the L-shaped end of the cable to the pad's OUTPUT jack.

Using a monaural cable will NOT allow rim shots or positional sensing.

MEMO

Refer to the table below for details on trigger inputs of sound modules supporting rim shots.

NOTE

* To prevent malfunction and equipment failure, always turn down the volume, and turn off all the units before making any connections.

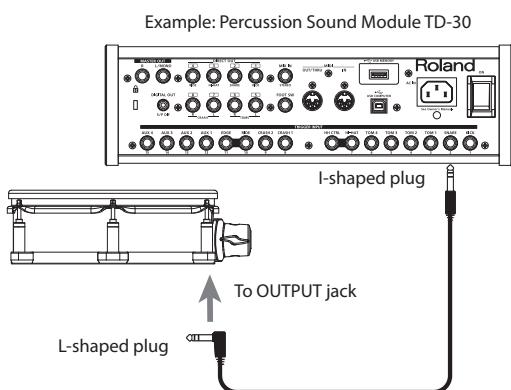

Trigger Parameter Settings on the Sound Module

Compatibility with Various Sound Modules

	Head Shot	Rim Shot	Cross Stick	Positional Sensing	Rim Shot Nuance	Brush Sweep
TD-30 TD-20X/ TDW-20/ TD-20	✓	✓	✓	✓	✓	✓
TD-12	✓	✓	✓	✓	✓	✓
TD-9	✓	✓	✓	—	—	—
TD-4	✓	✓	✓	—	—	—

MEMO

For details, refer to the owner's manual of your percussion sound module.

Recommended Parameter Settings

Below please find recommended trigger parameter settings when using the PD-128S/128/108 with various sound modules.

Further trigger parameter adjustment may be needed depending on the way in which the PD-128S/128/108 is mounted or the playing environment.

For details on editing refer to the owner's manual of your sound module.

TD-30	
Model name	Trigger type
PD-128S	PD128
PD-128	PD128
PD-108	PD108

- Trigger inputs that allow rim shots: SNARE, TOM 1–4, AUX 1–4
- Trigger inputs that allow cross-stick: SNARE
- Trigger inputs that allow positional sensing: SNARE, TOM 1–4, AUX 1–4

TD-20X/TDW-20/TD-20	
Model name	Trigger type
PD-128S	PD125
PD-128	PD125
PD-108	PD105

- Trigger inputs that allow rim shots: SNARE, TOM 1–4, AUX 1–4
- Trigger inputs that allow cross-stick: SNARE
- Trigger inputs that allow positional sensing: SNARE

TD-12	
Model name	Trigger type
PD-128S	PD125
PD-128	PD125
PD-108	PD105

- Trigger inputs that allow rim shots: SNARE, TOM 1–3, AUX 1–2
- Trigger inputs that allow cross-stick: SNARE
- Trigger inputs that allow positional sensing: SNARE

TD-9	
Model name	Trigger type
PD-128S	PD125
PD-128	PD125
PD-108	PD105

- Trigger inputs that allow rim shots:
SNARE, TOM 1–3, AUX
- Trigger inputs that allow cross-stick:
SNARE

TD-4	
Model name	Pad type
PD-128S	PD-125
PD-128	PD-125
PD-108	PD-105

- Trigger inputs that allow rim shots:
SNARE
- Trigger inputs that allow cross-stick:
SNARE

Adjusting the Head Tension

Before playing, you must adjust the pad tension first. You can tune/adjust the head tension as you would with an acoustic drum, to get the same dynamic “feel”

NOTE

- The pad will function at it's best if you are sure to:
 - Adjust the head evenly so that it does not sag.
 - Adjust the tuning bolts so that they are not loose.

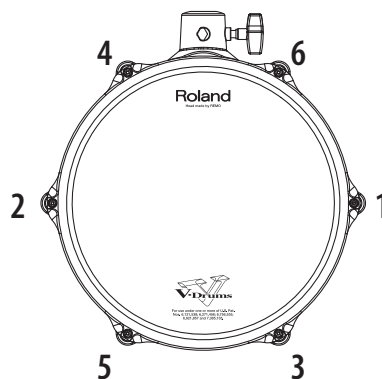

1. Adjust each tuning bolt little by little, across the head as indicated in the illustration.

NOTE

Fully tightening a tuning bolt at only a single location produces uneven tensioning, and correct playing dynamics may not be achieved or may even cause malfunctions. Even tuning/tensioning is very important.

2. Adjust the tightness of each tuning bolt so that the head is tensioned evenly.

MEMO

- Head tension will not affect the actual tuning of the sound you are playing. For that you need to adjust sound parameters in the sound module you are using. For details, refer to the owner's manual of your sound module.
- Also, head tension may change depending on usage. Adjust as needed.

Replacing the Head or Hoop Rubber

The performance of the head and/or hoop rubber will diminish with use over time. If the head is torn or becomes too fatigued, or impossible to tension correctly, then it should be replaced. If the hoop rubber is worn out, it too can be replaced.

For replacement heads or to have the hoop rubber replaced, please contact your dealer or a Roland service center.

Replacing the Head

NOTE

Applying excessive force to the sensor located under the head can damage it and/or interfere with accurate triggering.

1. Remove all tuning bolts.

Go around and loosen each bolt a little at a time by turning it counter-clockwise.

2. Remove the hoop and old head.

3. Place the new head and hoop on the shell

4. Install all six tuning bolts.

5. Adjust the tension of the head.

Refer to "Adjusting the head tension" above.

Replacing the Shell Covering

NOTE

- Applying excessive force to the sensor located under the head can damage it and/or interfere with accurate triggering.
- Be careful not to hurt your fingers on the corners or points of the metal parts.

1. Loosen all tuning bolts, and remove the hoop and head.

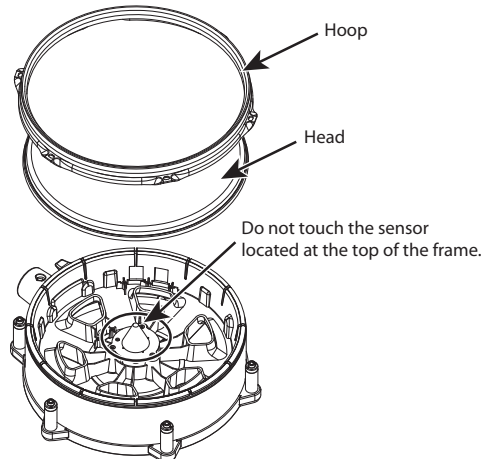

2. Remove the frame.

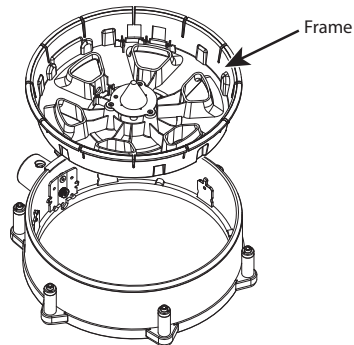

3. Use a Phillips screwdriver to loosen the screw that fastens the covering by approximately two full turns.

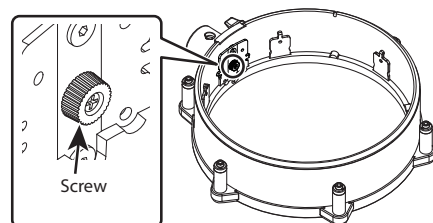

Connecting to the Percussion Sound Module

- 4.** Pull the fastening clip upward and out, and remove the covering.

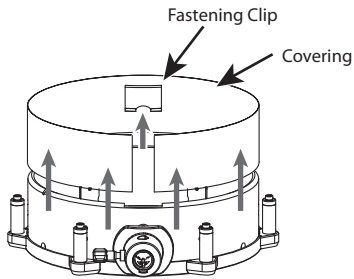

- 5.** Attach the new covering.

Insert the lower part of the covering into the rubber groove so that the upper edge of the covering is in the position shown in the illustration.

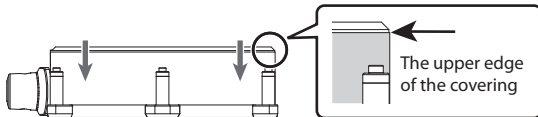

Both edges of the covering will fit into the gap between the shell and plate.

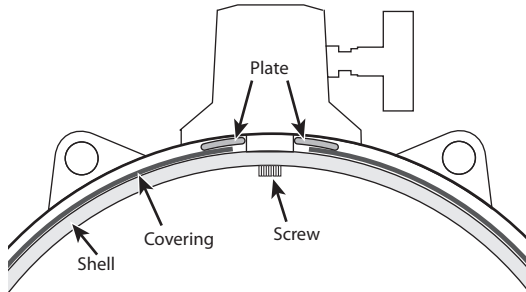

- 6.** While pulling on both ends of the covering so as to eliminate any slack, finger-tighten the screw that holds the covering in place.

- 7.** Using a Phillips screwdriver, securely fasten the screw that holds the covering in place.

- 8.** Attach the fastening clip in the location shown in the illustration, as if to pinch the two ends of the covering.

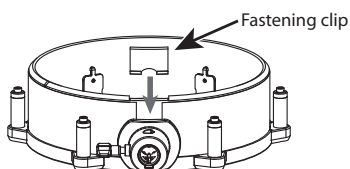

- 9.** Install the frame in the shell.

The frame's output jack will be pointing in the same direction as the bracket.

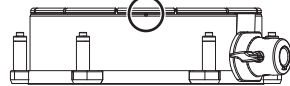
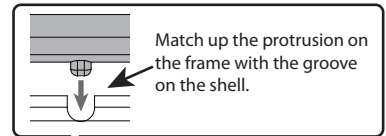
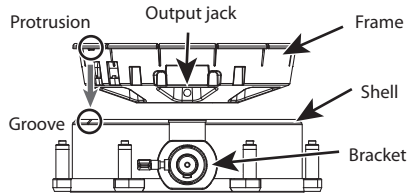

- 10.** Attach the hoop and head, and tighten the tuning bolts.

- 11.** Adjust the tension of the head.

Refer to "Adjusting the Head Tension" (p. 7).

Covering size

PD-128S/PD-128

- 77 (Width) x 927 (Length) mm

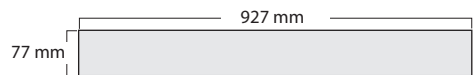

- Maximum Thickness: 1 mm

PD-108

- 77 (Width) x 767 (Length) mm



- Maximum Thickness: 1 mm

Playing Methods

Head Shots

Only playing the head and with certain snare sounds, the playing position will change the sound's nuance.

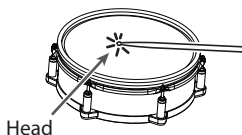

MEMO

See the TD-30/TD-20X/TDW-20/TD-20/TD-12 owner's manual for more info about which sounds allow this.

Rim Shots

Strike the head and the rim of the pad simultaneously.

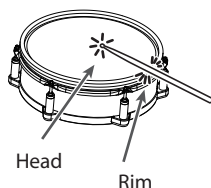

Cross Stick

Only strike the rim of the pad.

Depending on the instrument assigned to the rim you can play rim shots and/or cross stick sounds.

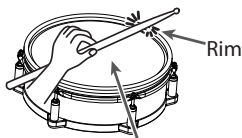

Do not place your hand on the head

NOTE

To play the cross stick, be sure that you only strike the rim of the pad. Placing your hand on the head of the pad might prevent the cross stick sound from being played properly.

Change the Nuance of the Rim Shot

Only with the TD-30/TD-20X/TDW-20/TD-20/TD-12

With certain snare and tom sounds, slight changes in the way you play rim shots changes the nuance.

Normal Rim Shots (Open Rim Shots)

Strike the head and rim simultaneously.

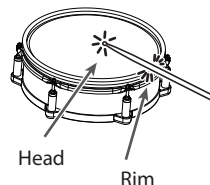

Shallow Rim Shots

Simultaneously strike the head near the rim and the rim itself.

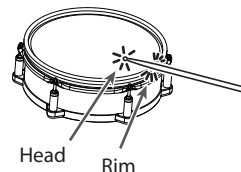

MEMO

- See the TD-30/TD-20X/TDW-20/TD-20/TD-12 owner's manual for more info about which sounds allow this.
- For more information on the trigger inputs of the various sound modules that support the use of rim shots, refer to p. 6.

Specifications

PD-128S

PD-128

PD-108: V-Pad

	PD-128S	PD-128	PD-108
Pad size	12 inches	12 inches	10 inches
Trigger	2 (Head, Rim)		
Bracket	—	✓	✓
Dimensions	358 (W) x 322 (D) x 117 (H) mm 14-1/8 (W) x 12-11/16 (D) x 4-5/8 (H) inches	358 (W) x 368 (D) x 117 (H) mm 14-1/8 (W) x 14-1/2 (D) x 4-5/8 (H) inches	307 (W) x 317 (D) x 117 (H) mm 12-1/8 (W) x 12-1/2 (D) x 4-5/8 (H) inches
Weights	3.0 kg 6 lbs 10 oz	3.4 kg 7 lbs 8 oz	3.0 kg 6 lbs 10 oz
Accessories	Owner's manual, Connection cable (*1), Drum key (*1) *1 Supplied only if the PD-128S/128/108 has been purchased as an independent unit.		
Options	—	Pad Mount (MDH series), Stand (MDS series)	

* In the interest of product improvement, the specifications and/or appearance of this unit are subject to change without prior notice.

For EU Countries



- UK** This symbol indicates that in EU countries, this product must be collected separately from household waste, as defined in each region. Products bearing this symbol must not be discarded together with household waste.
- DE** Dieses Symbol bedeutet, dass dieses Produkt in EU-Ländern getrennt vom Hausmüll gesammelt werden muss gemäß den regionalen Bestimmungen. Mit diesem Symbol gekennzeichnete Produkte dürfen nicht zusammen mit den Hausmüll entsorgt werden.
- FR** Ce symbole indique que dans les pays de l'Union européenne, ce produit doit être collecté séparément des ordures ménagères selon les directives en vigueur dans chacun de ces pays. Les produits portant ce symbole ne doivent pas être mis au rebut avec les ordures ménagères.
- IT** Questo simbolo indica che nei paesi della Comunità europea questo prodotto deve essere smaltito separatamente dai normali rifiuti domestici, secondo la legislazione in vigore in ciascun paese. I prodotti che riportano questo simbolo non devono essere smaltiti insieme ai rifiuti domestici. Ai sensi dell'art. 13 del D.Lgs. 25 luglio 2005 n. 151.
- ES** Este símbolo indica que en los países de la Unión Europea este producto debe recogerse aparte de los residuos domésticos, tal como está regulado en cada zona. Los productos con este símbolo no se deben depositar con los residuos domésticos.
- PT** Este símbolo indica que nos países da UE, a recolha deste produto deverá ser feita separadamente do lixo doméstico, de acordo com os regulamentos de cada região. Os produtos que apresentem este símbolo não deverão ser eliminados juntamente com o lixo doméstico.
- NL** Dit symbool geeft aan dat in landen van de EU dit product gescheiden van huishoudelijk afval moet worden aangeboden, zoals bepaald per gemeente of regio. Producten die van dit symbool zijn voorzien, mogen niet samen met huishoudelijk afval worden verwijderd.
- DK** Dette symbol angiver, at i EU-lande skal dette produkt opsamles adskilt fra husholdningsaffald, som defineret i hver enkelt region. Produkter med dette symbol må ikke smides ud sammen med husholdningsaffald.
- NO** Dette symbolet indikerer at produktet må behandles som spesialavfall i EU-land, iht. til retningslinjer for den enkelte regionen, og ikke kastes sammen med vanlig husholdningsavfall. Produkter som er merket med dette symbolet, må ikke kastes sammen med vanlig husholdningsavfall.

- SE** Symbolen anger att i EU-länder måste den här produkten kasseras separat från hushållsavfall, i enlighet med varje regions bestämmelser. Produkter med den här symbolen får inte kasseras tillsammans med hushållsavfall.
- FI** Tämä merkintä ilmaisee, että tuote on EU-maissa kerättävä erillään kotitalousjätteistä kunkin alueen voimassa olevien määräysten mukaisesti. Tällä merkinnällä varustettuja tuotteita ei saa hävittää kotitalousjätteiden mukana.
- HU** Ez a szimbólum azt jelenti, hogy az Európai Unióban ezt a terméket a háztartási hulladéktól elkülönítve, az adott régióban érvényes szabályozás szerint kell gyűjteni. Az ezzel a szimbómmal ellátott termékeket nem szabad a háztartási hulladék közé dobni.
- PL** Symbol oznacza, że zgodnie z regulacjami w odpowiednim regionie, w krajach UE produktu nie należy wyrzucać z odpadami domowymi. Produktów opatrzonych tym symbolem nie można utylizować razem z odpadami domowymi.
- CZ** Tento symbol udává, že v zemích EU musí být tento výrobek sbírán odděleně od domácího odpadu, jak je určeno pro každý region. Výrobky nesoucí tento symbol se nesmí vyhazovat spolu s domácím odpadem.
- SK** Tento symbol vyjadruje, že v krajinách EÚ sa musí zber tohto produktu vykonávať oddelene od domového odpadu, podľa nariadení platných v konkrétnej krajine. Produkty s týmto symbolom sa nesmú vyhazovať spolu s domovým odpadom.
- EE** See sümbol näitab, et EL-i maades tuleb see toode olemprügist eraldi koguda, nii nagu on igas piirkonnas määratletud. Selle sümboliga märgitud tooteid ei tohi ära visata koos olmeprügiga.
- LT** Šis simbolis rodo, kad ES šalyse šis produktas turi būti surenkamas atskirai nuo buitinių atliekų, kaip nustatyta kiekviename regione. Šiuo simboliu paženklinėti produktai neturi būti išmetami kartu su buitinėmis atliekomis.
- LV** Šis simbols norāda, ka ES valstīs šo produktu jāievāc atsevišķi no mājsaimniecības atkritumiem, kā noteikts katrā reģionā. Produkta ar šo simbolu nedrīkst izmest kopā ar mājsaimniecības atkritumiem.
- SI** Ta simbol označuje, da je treba proizvod v državah EU zbirati ločeno od gospodinjskih odpadkov, tako kot je določeno v vsaki regiji. Proizvoda s tem znakom ni dovoljeno odlagati skupaj z gospodinjskimi odpadki.
- GR** Το σύμβολο αυτό υποδηλώνει ότι στις χώρες της Ε.Ε. το συγκεκριμένο προϊόν πρέπει να συλλέγεται χωριστά από τα υπόλοιπα οικιακά απορρίμματα, σύμφωνα με όσα προβλέπονται σε κάθε περιοχή. Τα προϊόντα που φέρουν το συγκεκριμένο σύμβολο δεν πρέπει να απορρίπτονται μαζί με τα οικιακά απορρίμματα.

For China

有关产品中所含有害物质的说明

本资料就本公司产品中所含的特定有害物质及其安全性予以说明。
本资料适用于 2007 年 3 月 1 日以后本公司所制造的产品。

环保使用期限



此标志适用于在中国国内销售的电子信息产品，表示环保使用期限的年数。所谓环保使用期限是指在自制造日起的定期限内，产品中所含的有害物质不致引起环境污染，不会对人身、财产造成严重的不良影响。
环保使用期限仅在遵照产品使用说明书，正确使用产品的条件下才有效。
不当的使用，将会导致有害物质泄漏的危险。

产品中有毒有害物质或元素的名称及含量

部件名称	有毒有害物质或元素					
	铅(Pb)	汞(Hg)	镉(Cd)	六价铬(Cr(VI))	多溴联苯(PBB)	多溴二苯醚(PBDE)
外壳(壳体)	×	○	○	○	○	○
电子部件(印刷电路板等)	×	○	×	○	○	○
附件(电源线、交流适配器等)	×	○	○	○	○	○

○：表示该有毒有害物质在该部件所有均质材料中的含量均在 SJ/T11363-2006 标准规定的限量要求以下。
×：表示该有毒有害物质至少在该部件的某一均质材料中的含量超出 SJ/T11363-2006 标准规定的限量要求。
因根据现有的技术水平，还没有什么物质能够代替它。

For C.A. US (Proposition 65)

WARNING

This product contains chemicals known to cause cancer, birth defects and other reproductive harm, including lead.

